

Clermont parkrun Lake Hiawatha One Loop 5K
 Clermont, FL

List of Measured Points

Map is not to scale.
Points are marked with yellow paint on the road.

Start/Finish – On the South Lake Trail, even with the first light pole just south of the pavilion on the lake shore at Lake Hiawatha Preserve. 21 feet 7 inches south of the south edge of the pavilion. 28.570082 -81.779187

Mile 1 – On the South Lake Trail. 28.557843 -81.772272

Turnaround – On the South Lake Trail. 29 feet 2 inches northeast of the northeast edge of the dock nearest to the traffic circle at the north terminus of 5th Street. 28.558967 - 81.763568

Mile 2 – On the South Lake Trail. 28.57446 -81.770496

Mile 3 – On the South Lake Trail. 28.568843 -81.778132

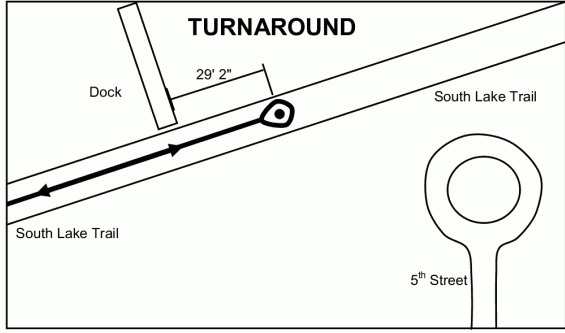
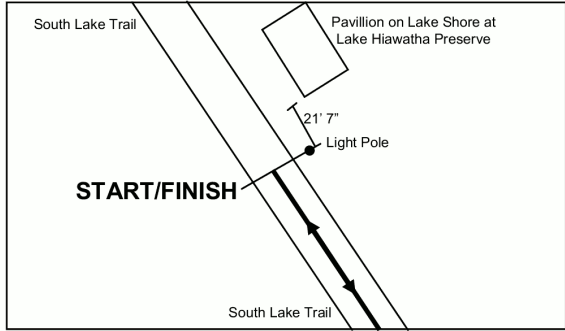

Measured by: Jacob Smith
 Measured on: 04/19/2017
 Jacob@RaceSmith.com



**Road Running Technical Council
USA Track & Field
Measurement Certificate**



Name of course: Clermont Parkrun Lake Hiawatha One Loop 5k Distance: 5 km

Location : (state) Florida (city) Clermont

Type of course : road race calibration course

Measuring method : bicycle steel tape electronic distance meter

Measured by (name, address, phone & e-mail) Jacob Smith 114 Oak Lane, East Palatka, Florida 32131
386-747-3532 racesmith@hotmail.com

Race Contact (name, address, phone & email) Jacob Smith 114 Oak Lane, East Palatka, Florida 32131
386-747-3532 racesmith@hotmail.com

Date(s) when course measured: Apr. 19, 2017

Number of measurements of entire course: 2 Course Configuration: same out/ back 1 time

Elevation (meters above sea level) Start 31 m Finish 31 m Highest 33 m Lowest 30 m

Straight line distance between start & finish 0 m Drop 0 m/km Separation 0.0%

Type of Surface: Paved 100% Dirt 0% Gravel 0% Grass 0% Track 0%

Effective date of certification: Apr. 23, 2017 Certification code: FL17032TY

Notice to Race Director: Use this Certification code
in *all* public announcements relating to your race

Be It Officially Noted That

Based on examination of data provided by the above named measurer, the course described above and in the map attached is hereby certified as reasonably accurate in measurement according to the standards adopted by the Road Running Technical Council. If any changes are made to the course, this certification becomes void, and the course must then be recertified.

Verification of Course — In the event a National Open Record is set on this course, or at the discretion of USA Track & Field, a verification remeasurement may be required to be performed by a member of the Road Running Technical Council. If such a remeasurement shows the course to be short, then all pending records will be rejected and the course certification will be cancelled.

This certification expires on December 31 in the year

2027

AS NATIONALLY CERTIFIED BY

Date : May. 30, 2017

Toni Youngman - USATF/RRTC Certifier - 12895 Downstream Circle, Orlando, FL 23828 - (407)619-2797 -
toni@runzamok.net